

4003 LoRa Module Lithium Battery Option Operating Manual //

CONTENTS		Page
1.	GENERAL DESCRIPTION	2
2.	ASSEMBLY	2
3.	PROGRAMMING THE LoRa PCB	3
4.	OPERATION	4

1. GENERAL DESCRIPTION

The Online 4003 LoRa Module is an optional PCB fitted to the 4003 Magnetic Pig Signaller enabling radio transmission over a 'LoRa' network. The module incorporates a Murata CMWX1ZZABZ-078 LoRa module. This module is pre-certified for operation in various regions worldwide (e.g. FCC ID:VPYCMABZ).

The 4003 and the LoRa PCB are powered by 2 off Lithium D Cells (see the 4003 manual for recommended battery details). The LoRa PCB is only powered by the battery option supplied and not by any external power.

2. ASSEMBLY

The 4003 LoRa PCB is located on the pillars supporting the 4003 Display PCB as shown below.

In addition an ATEX certified antenna suitable for the region of use is fitted to one of the entries on the 4003D enclosure and attached to the SMA connector on the 4003 LoRa PCB.

The LoRa module is activated by connecting the wire connected to the 'CT1_LNK' pad on the PCB to 0V. This is achieved in the 4003 by connecting this wire (pink wire shown in the picture opposite) to one of the normally open contacts of the 4003 relay which has its common connection connected to 0V on the 4003 Interface PCB. Connections to the relay are made via pluggable connectors on the 4003 Interface PCB to aid installation.

When a pig is detected, and signalled, the 4003 activates the relay for a period defined by the 'DELAY TIME' (see 4003 Operation Manual). This will power up the LoRa module for this time during which transmission of the pig passage to the LoRa network can be made.

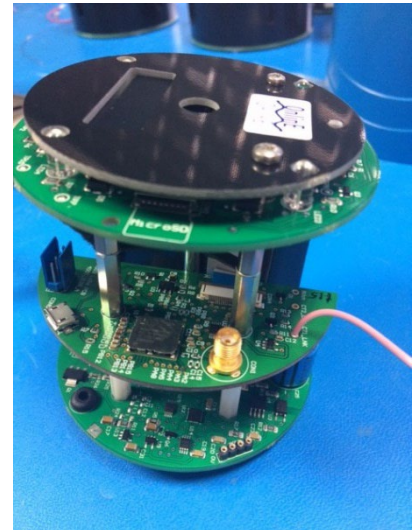

3. PROGRAMMING THE LoRa PCB

NOTE: Lithium batteries should not be fitted in the 4003 until programming, testing and verification are complete.

The end user has to program the 4003 LoRa Module (Murata CMWX1ZZABZ-078) with suitable firmware and LoRa Network 'keys' to enable operation.

To enable this a USB lead is supplied (type A to micro B connector) to power the 4003 LoRa PCB whilst programming and testing. This basically provides a 5V supply to the 4003 LoRa PCB which, when connected to a USB power supply or a computer, will immediately power up the PCB and does not require the 'CT1_LNK' connection.

A ST-Link/V2 programming adapter is supplied along with a 'programming lead' which connects to the ST-LINK/V2 (IDC connector) and the 4003 LoRa PCB (4-way TE Connectivity straight connector). Using suitable ST32 development and programming software enables programming of the 'user program' to the LoRa module.

It is advised to have an antenna fitted to the PCB as allowing the PCB to drive an open circuit connection may damage the LoRa module. Two antenna leads are supplied which can be used.

For ease of development and programming of the 4003 LoRa PCB the 4003 PCB stack can be removed from the 4003 (see 4003 Operating Manual) and power applied to the 4003 LoRa PCB via the USB lead. Once programming is complete the 4003 PCB stack can be re-fitted with the connections to the 4003 Interface PCB made and the antenna connected.

It is advised that the current drawn by the 4003 is verified prior to fitting the batteries. This can be done by attaching an external power supply to the battery contacts with a voltage set between 6 – 9 V dc. A suitable current meter should be connected in series (or use made of the external power supply current meter if present).

When the 4003 detects a pig the total average current drawn should be < 30mA (typically 25mA). It has been observed that the LoRa module does pulse current during transmission. The repetition rate of these pulse is defined by the 'user program' and hence the overall average current will also increase or decrease dependant on how often the LoRa module is transmitting.

Monitoring this current confirms the expected currents and therefore safe operation when the Lithium batteries are fitted. If an average current of > 30mA is present then it should be considered that there may be a fault and OEL should be contacted for advice.

If the current measured is within the limits stated above then the batteries can be fitted. The USB lead and programming leads can be left connected when the batteries are present but the batteries will be supplying power to the unit as there voltage > USB supply voltage assuming the 4003 is powered up. The USB lead will supply power if the 4003 is powered down.

4. OPERATION

There are numerous development environments that can be used for programming the STM32L082 microprocessor used in the Murata CMWX1ZZABZ-078 module e.g. Keil, IAR, System Workbench etc. and creating the necessary 'bin' file for download to the microprocessor using the ST-LINK/V2 adapter. Programs cannot be downloaded or debugged using the USB lead at present.

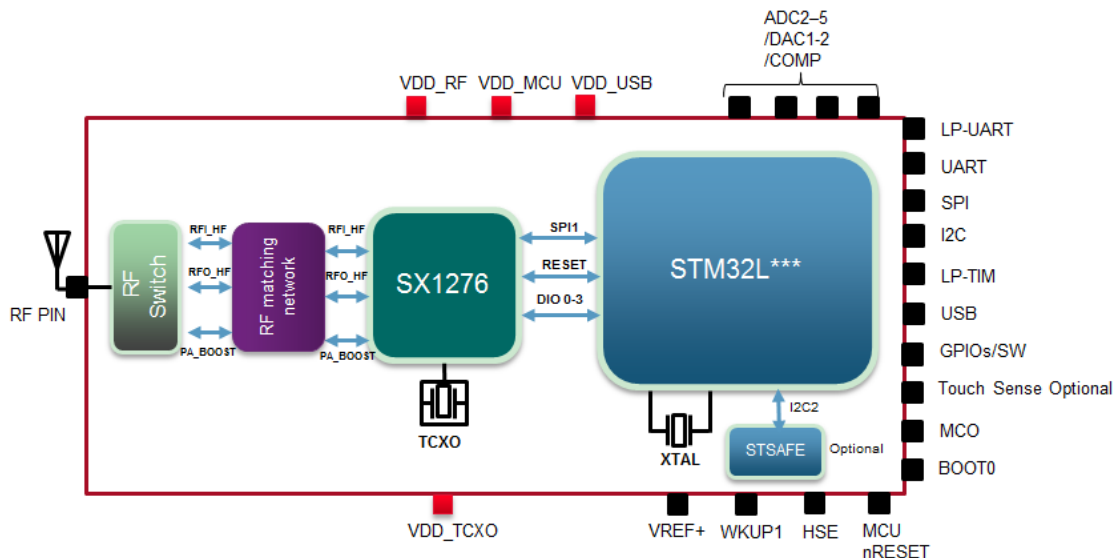

None of the port pins made available on the Murata CMWX1ZZABZ-078 module are connected on the 4003 LoRa PCB. The user can configure these pins as desired possibly for debugging purposes as pads connected to these pins are made available on the 4003 LoRa PCB.

The user can implement low power operation schemes in the LoRa module in order to reduce battery power consumption.