

3015X Alkaline Series Electromagnetic Transmitter Operating Manual

The 3015X transmitter is an electromagnetic transmitter that can be used for pig tracking and locating functions, intended for use in pipeline diameters above 10”



Online Electronics Limited
+44 (0) 1224 714 714
OEL-Sales@ik-worldwide.com
online-electronics.com

CONFIGURATION INFORMATION	
SERIAL NUMBER:	
OUTPUT SIGNAL:	
REPETITION RATE 1:	
RATE 1 BATTERY LIFE AT +20°C:	
REPETITION RATE 2:	
RATE 2 BATTERY LIFE AT +20°C:	

3015_5001

Rev	Date	By	Summary of change
A00	03/08/17	BG	CR00485: Was 3015X ATEX ALKALINE EM TRANSMITTER MANUAL RevB02. CR00380: Address change. CR00499: Front cover update.
A01	09/10/17	BG	CR0049: Cover page update
A02	23/07/18	BG	CR00401: Format, graphics. CR00528: Endcap Removal Tool usage
B00	21/01/20	TL	CR00841: Notified Body Number & Email address updated
B01	13/10/20	TL	CR00947 & CR01039 New Front Page
B02	06/04/22	TL	CR01116: Pipeline sizes updated

COMMENTS:

CONTENTS

Page

1. GENERAL DESCRIPTION 4

2. SPECIFICATIONS..... 5

3. RULES FOR SAFE OPERATION 6

4. OPERATION 7

 4.1. TURNING ON..... 7

 4.2. TURNING OFF 7

 4.3. FUNCTION TEST 8

 4.4. DEPLOYMENT 8

 4.5. MODE SELECT 9

 4.6. INSTALLATION 10

 4.7. BATTERY LIFETIME 11

 4.8. BATTERY REPLACEMENT 12

5. MAINTENANCE 13

 5.1. O-RING REPLACEMENT..... 13

 5.2. ROUTINE MAINTENANCE AND STORAGE 14

6. DISPOSAL OF UNIT 15

7. WARRANTY 15

8. APPENDIX A – ATEX SPECIFIC INSTRUCTIONS 16

1. GENERAL DESCRIPTION

The 3015X Electromagnetic transmitter is an ATEX certified EM transmitter used for pig tracking and location functions. The transmitter operates effectively in buried pipelines, pipelines carrying gas and in pipeline bundles where acoustic transmitters are either less effective or ineffective.

The transmitter emits a 21.8Hz signal and an inherent EM null spot is detectable when the EM receiver antenna is at 90 degrees to and pointing at the centre of the transmitter allowing centimetre accurate positioning of a pig.

The transmitter can be changed between two pulsing transmission rates via an easily accessible slide switch inside the transmitter.

It is possible to detect the EM transmissions from a 3015X transmitter through pipeline walls in excess of 40mm thick, however performance is dependent on several factors including the type of receiver and antenna used, distance between antenna and transmitter, pig design, pig speed, pipeline diameter, pipeline material and background EM noise levels. Please contact OEL to discuss the most effective configuration.

A non-ATEX version of the transmitter can be manufactured with specially designed endcaps which allow fitting of pigging discs directly to the transmitter - the transmitter itself becomes the pig body. This dramatically increases the received EM signal because it no longer needs to propagate through an additional pig body as well as the pipeline.

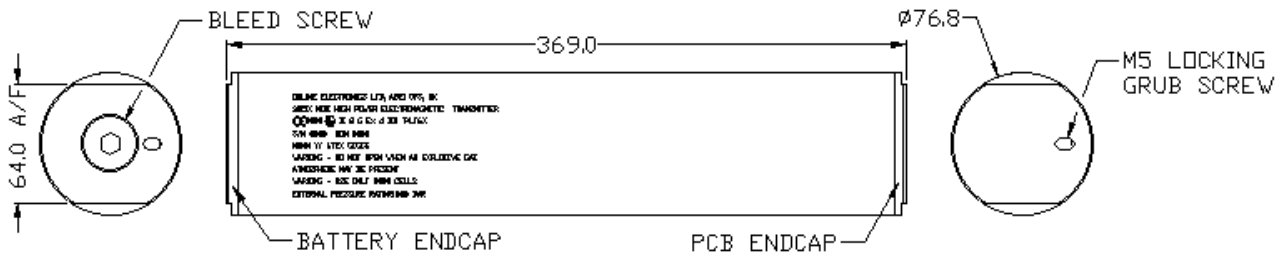

Parameters such as lifetime, pulse rate, frequency and output level can be customised during manufacture, please contact Online Electronics Ltd for more details.

2. SPECIFICATIONS

NOTE THAT THE SPECIFICATIONS BELOW ARE VALID FOR THE STANDARD CONFIGURATION ONLY. REFER TO PAGE 1 OF THIS MANUAL FOR THE CONFIGURATION INFORMATION SPECIFIC TO THE TRANSMITTER BEING USED.

GENERAL:

Lifetime in continuous mode at +20°C in air	5 days
Lifetime pulsing 0.4sec ON / 0.6sec OFF at +20°C in air	9 days
Lifetime pulsing 0.4sec ON / 1.6sec OFF at +20°C in air	17 days
Lifetime pulsing 0.4sec ON / 2.6sec OFF at +20°C in air	25 days
Lifetime pulsing 0.4sec ON / 3.6sec OFF at +20°C in air	31 days
Lifetime pulsing 0.4sec ON / 4.6sec OFF at +20°C in air	37 days
Alkaline batteries.....	5x DURACELL INDUSTRIAL ID1300 ALKALINE D CELLS
Standard signal at 1m with OEL reference antenna at +20°C in air	624mVpp
Standard frequency	21.8Hz
Operating temperature range.....	-20 to +54°C
External pressure rating	500bar
Bump rating.....	20G
Weight in air (including batteries).....	7kg

MATERIALS:

Housing material	ASTM B348 GRADE 5 TITANIUM Ti-6Al-4V
Endcap material	ALLOY BRONZE CA104 EN 12163
Bleedscrew material.....	316 STAINLESS STEEL EN 1.4401
O-rings	NBR70 (standard) / FKM936 (heavy duty)

ATEX:

Notified body number.....	2812
Type examination number	TRAC 09 ATEX 21218 X
Code.....	Ex II 2 G Ex d IIB T4..T6X

3. RULES FOR SAFE OPERATION

⚠ WARNING: The Special Conditions for Safe Use as detailed in Section 8 APPENDIX A – ATEX SPECIFIC INSTRUCTIONS must be followed at all times.

⚠ WARNING: Any operation involving pressure is potentially hazardous. No person should use this equipment unless fully aware of the potential hazards of working with pressurised vessels. The purchaser of this equipment is responsible for the training and competence of operators and the manner in which it is used. This manual should be read through and understood before installation and commissioning so that the operator is familiar with the equipment. Contact Online Electronics Ltd immediately should any difficulty arise in the use of this equipment.

⚠ WARNING: DO NOT open when an explosive atmosphere may be present. Always use caution when opening equipment which has been in a pressurised environment. It is possible for pressure to leak into the equipment and remain there even after external pressure has been removed. ALWAYS point the end to be opened towards a safe area and away from yourself or others. Contact Online Electronic immediately if there is a suspicion that the equipment has become pressurised.

⚠ WARNING: Only DURACELL INDUSTRIAL ID1300 ALKALINE cells are permitted to be used in this equipment.

⚠ WARNING: Replace all batteries at the same time. NEVER install used batteries. NEVER install a mix of new and used batteries. USE ONLY new batteries from the same package or manufacturing batch. DO NOT mix different brands or types of batteries. ALWAYS observe correct battery polarity. New batteries should be installed before each deployment.

⚠ WARNING: Do not expose to aggressive solvents or chemicals which could be harmful to the HOUSING, O-RINGS, CONNECTORS or any other parts of the equipment.

⚠ CAUTION: Opening of the equipment should take place in a clean laboratory environment.

⚠ CAUTION: To prevent the formation of condensation within the transmitter, allow the transmitter temperature to stabilise within the laboratory environment for a minimum of 6 hours prior to opening.

⚠ CAUTION: It is possible for liquids to become trapped in threads and/or gaps around openings. ALWAYS point the end to be opened downwards to allow any trapped liquid to drain out of and not into the equipment.

⚠ CAUTION: If the transmitter is to be placed in storage, always ensure that it is turned OFF and the batteries are removed and stored separately.

4. OPERATION

Familiarise yourself with all of the rules for the safe operation of this equipment as described in Section 3 RULES FOR SAFE OPERATION.

4.1. TURNING ON

1. To turn the transmitter on, fully tighten the bleed screw using the supplied ENDCAP REMOVAL TOOL or a 10mm AF Allen key. Do not use excessive torque. The transmitter takes approximately 5 seconds to turn on. Note that the transmitter is usually shipped with a Nylon washer under the bleed screw to prevent accidental activation during transport. This must be removed before the transmitter can be turned on.
2. Use an EM receiver system to confirm that the transmitter is functioning properly at the expected pulse rate.

4.2. TURNING OFF

1. To turn the transmitter off, loosen the bleed screw 3 full turns using the supplied ENDCAP REMOVAL TOOL or a 10mm AF Allen key. To prevent the bleed screw being lost, or the transmitter accidentally being turned back on, the bleed screw should be held in this position with some tape.
2. Use an EM receiver system to confirm that the transmitter has turned off.

4.3. FUNCTION TEST

An OEL EM receiver system is required to receive the signal from a 3015X transmitter. Refer to the relevant EM receiver manual for instruction on setup and operation of the EM receiver system.

1. Place the EM receiver antenna approximately 10m away and parallel to the transmitter.
2. Activate the transmitter as detailed in Section 4.1 TURNING ON.
3. Confirm that a clear signal is received.
4. Switch the transmitter between OFF, RATE 1 and RATE 2 several times to ensure that the signal received reacts as expected. Refer to Section 4.5 MODE SELECT for further information on changing transmission rates.
5. An inherent null spot is detectable when the antenna is at 90 degrees to and pointing at the centre of the transmitter allowing accurate positioning of a pig. Refer to the relevant EM receiver manual for further information.
6. Turn OFF the transmitter as detailed in Section 4.2 TURNING OFF.
7. If all results were as expected then the system is functional.

4.4. DEPLOYMENT

Before each deployment ensure that the following checks have been completed.

1. Ensure that the transmitter has been installed as detailed in Section 4.6 INSTALLATION.
2. Visually inspect all system components to ensure that they are secure and undamaged.
3. Refer to the Page 1 of this manual for the expected battery lifetime and ensure that it is adequate for the planned operations.
4. Activate the transmitter as detailed in Section 4.1 TURNING ON.
5. Complete a 4.3 FUNCTION TEST.

4.5. MODE SELECT

1. Familiarise yourself with all of the warnings given at the start of Section 3 RULES FOR SAFE OPERATION.
2. If not already loosened, using the supplied ENDCAP REMOVAL TOOL or a 10mm AF Allen key, loosen the bleed screw 3 full turns to release any internal pressure and to turn the transmitter off. There is no need to fully remove the bleed screw. If you do so it may be lost.
3. Using a 2.5mm AF Allen key fully unscrew the M5 locking grub screw on the PCB ENDCAP. The grub screw may be screwed back in 3 turns to prevent it getting lost.
4. Using the supplied ENDCAP REMOVAL TOOL, fully remove the PCB ENDCAP to reveal the PCB assembly and switch as shown in the figure below.

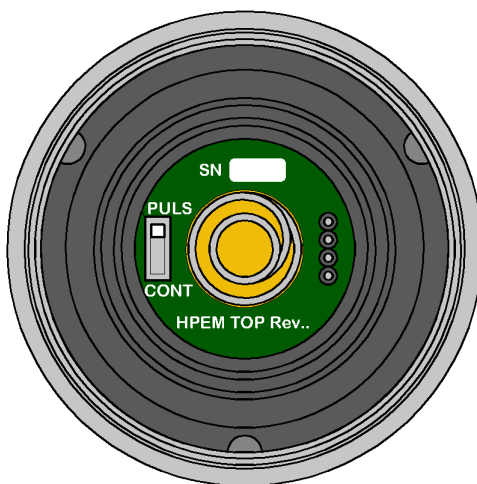

5. Set the MODE SWITCH to the desired position. The switch can be set to either RATE 1 (switch in upper position or PULS) or RATE 2 (switch in lower position or CONT). Refer to the cover of this manual for the rates available for the transmitter being used.
6. Examine the O-ring seals for any signs of contamination or damage, replace and/or re-grease if necessary.
7. Replace the PCB ENDCAP using the supplied ENDCAP REMOVAL TOOL. Do not use a vice or spanner, it only needs to be hand tight. Damage may occur if over tightened.
8. Tighten the M5 grub screw (until the grub screw engages with the housing to lock the PCB ENDCAP). Note that very little torque is required. Damage may occur if over tightened.
9. Fully tighten the bleed screw to turn on the transmitter. Use an EM receiver system to confirm transmitter function and correct transmission rate.
10. If the transmitter is not to be used immediately after the mode has been selected, loosen the bleed screw 3 full turns to switch the transmitter off and use some tape to hold the bleed screw in this position to prevent it being lost or the transmitter being accidentally turned back on.

4.6. INSTALLATION

⚠ WARNING: The Special Conditions for Safe Use as detailed in Section 8 APPENDIX A – ATEX SPECIFIC INSTRUCTIONS must be followed at all times.

⚠ WARNING: The transmitter must be mounted in such a way that no movement or vibration whatsoever is possible (e.g. clamped). If the transmitter is allowed to rattle and/or vibrate within the pig then the resultant hammering effect can exceed the bump rating of the transmitter leading to damage and/or failure. This is particularly important in gas pipelines.

⚠ CAUTION: All EM transmitters will induce electrical currents in any conductive materials closely surrounding them which can result in a severe reduction in signal strength and/or battery lifetime. This effect can be minimised by reducing the amount of conducting material surrounding the transmitter. Leave as much of the transmitter exposed as possible. Any slits or apertures which can be made in the surrounding material will help. Use materials with as high resistance as possible. Non-conducting materials such as plastics will not suffer from this effect. EM transmitters must not be surrounded by low resistance metals such as aluminium (including tubes or mounting clamps) under any circumstances.

⚠ CAUTION: Any magnetic material surrounding the transmitter will tend to block the EM signal from the transmitter and reduce the received signal strength outside the pipeline. This effect can be minimised by reducing the amount of magnetic material surrounding the transmitter. Leave as much of the transmitter exposed as possible. Any slits or apertures which can be made in the surrounding material will help. Use materials with as low magnetic permeability as possible. Non-magnetic materials such as plastics will not suffer from this effect. The table below shows the typical characteristics of several potential pig and mounting materials with the best choice at the top, and the worst choice at the bottom. 316 stainless steel provides a good balance of properties and cost. An aluminium alloy would be a very poor choice because of the very low resistivity and should not be used under any circumstances.

MATERIAL	RESISTIVITY ($\mu\Omega.m$)	MAGNETIC PERMEABILITY
PLASTIC	∞	1.000
316 STAINLESS STEEL	0.75	1.008
2205 DUPLEX SS	0.80	>25.0
1005 STEEL	0.20	>100
ALUMINIUM ALLOYS	0.04	1.000

For optimum performance the transmitter should be clamped inside a plastic pig body or plastic guide discs should be clamped around the transmitter to form a pig. The advantage of these methods is the fact that there is no metal around the transmitter apart from the pipeline itself. Two alternative mounting arrangements are shown below. The first uses several lengths of threaded studding to clamp the transmitter between two plates. The second uses a clamping disc. The advantage of these arrangements is that they have limited amounts of metal around the transmitter and will therefore have limited effect on the transmitter performance. Please contact Online Electronics for further information and guidelines regarding EM transmitter mounting and installation.

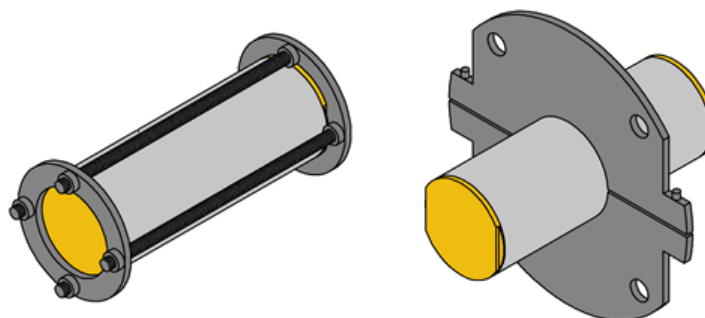

4.7. BATTERY LIFETIME

The operating temperature which the transmitter is used at alters the operating lifetime. Typically colder temperatures will shorten the stated lifetime as shown by the figure below.

Note that upon customer request, the transmitters can be adjusted at Online Electronics Ltd to provide a stronger signal at the expense of lifetime or extended lifetime at the expense of signal, contact Online Electronics Ltd for more details and to discuss your requirements.

In extreme circumstances the transmitter operating lifetime may be reduced by how the transmitter is installed on a pig. For example, if it is installed inside an aluminium tube, the operating lifetime may be reduced to as little as 50%. Refer to Section 4.6 INSTALLATION within this manual for tips on how to achieve optimum performance from the transmitter with regards to the mounting arrangement.

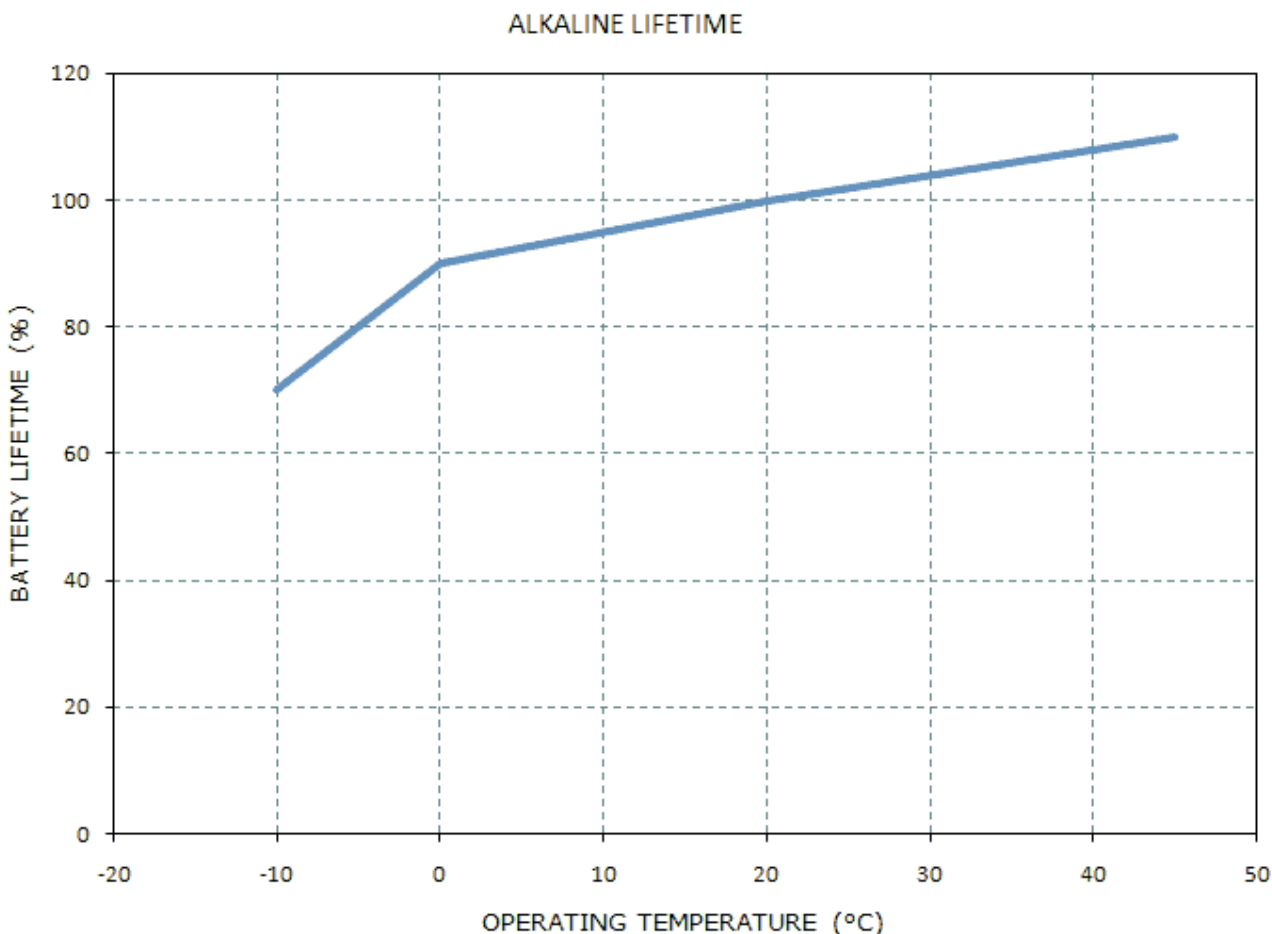

4.8. BATTERY REPLACEMENT

1. Familiarise yourself with all warnings given at the start of Section 3 RULES FOR SAFE OPERATION.
2. Using the supplied ENDCAP REMOVAL TOOL or a 10mm AF Allen key loosen the bleed screw 3 full turns to release any internal pressure and to turn the transmitter off. There is no need to fully remove the bleed screw. If you do so it may be lost.
3. Using a 2.5mm AF Allen key fully unscrew the M5 locking grub screw on the BATTERY ENDCAP. The grub screw may be screwed back in 3 turns to prevent it getting lost.
4. Using the supplied ENDCAP REMOVAL TOOL, fully remove the BATTERY ENDCAP.
5. Remove all DURACELL INDUSTRIAL ID1300 Alkaline D cells and battery discs. Visually inspect the batteries, contact Online Electronics Ltd immediately if there are any signs of damage or electrolyte leakage. Dispose of the old batteries in a responsible way. Place the battery discs safely to the side so they don't get lost.
6. Observing the battery polarity shown in the figure below, insert 5x new DURACELL INDUSTRIAL ID1300 Alkaline D cells into the battery compartment POSITIVE END first with an ALK BATTERY DISC between neighbouring cells. A total of 4x battery discs will be required.

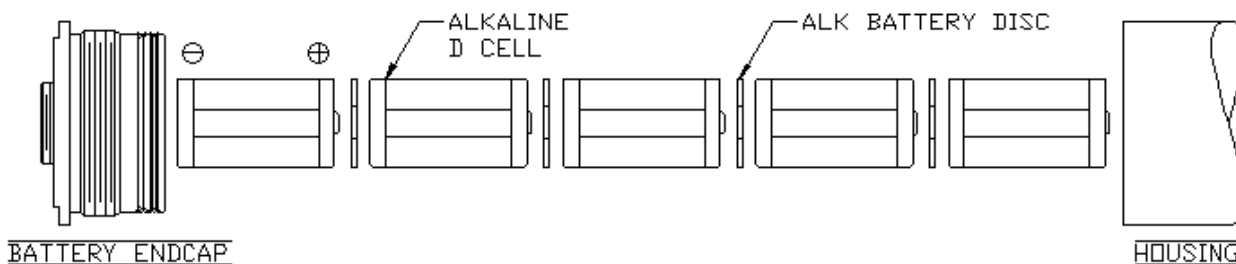

7. Once all batteries are installed ensure that it is the FLAT, NEGATIVE END of the batteries which you see when looking into the open end of the transmitter.
8. Examine the O-ring seals for any signs of contamination or damage, replace and/or re-grease if necessary.
9. Replace the BATTERY ENDCAP using the supplied ENDCAP REMOVAL TOOL. Do not use a vice or spanner, it only needs to be hand tight. Damage may occur if over tightened.
10. Tighten the M5 grub screw (until the grub screw engages with the housing to lock the BATTERY ENDCAP). Note that very little torque is required. Damage may occur if over tightened.
11. Fully tighten the bleed screw to turn on the transmitter. Using an EM receiver, confirm transmitter function and correct transmission rate.
12. If the transmitter is not to be used immediately after battery replacement, loosen the bleed screw 3 full turns to switch the transmitter off and use some tape to hold the bleed screw in this position to prevent it being lost or the transmitter being accidentally turned back on.

5. MAINTENANCE

Familiarise yourself with all of the rules for the safe operation of this equipment as described in Section 3 RULES FOR SAFE OPERATION.

5.1. O-RING REPLACEMENT

1. Familiarise yourself with all of the warnings given at the start of Section 5 MAINTENANCE.
2. Using the supplied ENDCAP REMOVAL TOOL or a 10mm AF Allen key fully remove the bleed screw.
3. Using a 2.5mm AF Allen key fully unscrew the M5 locking grub screw on the PCB and BATTERY ENDCAPS. The grub screws may be screwed back in 3 turns to prevent them getting lost.
4. Using the supplied ENDCAP REMOVAL TOOL, fully remove the BATTERY ENDCAP, any batteries and battery discs, then the PCB ENDCAP.
5. Referring to the figure below, remove all O-rings and clean all sealing surfaces on all parts.

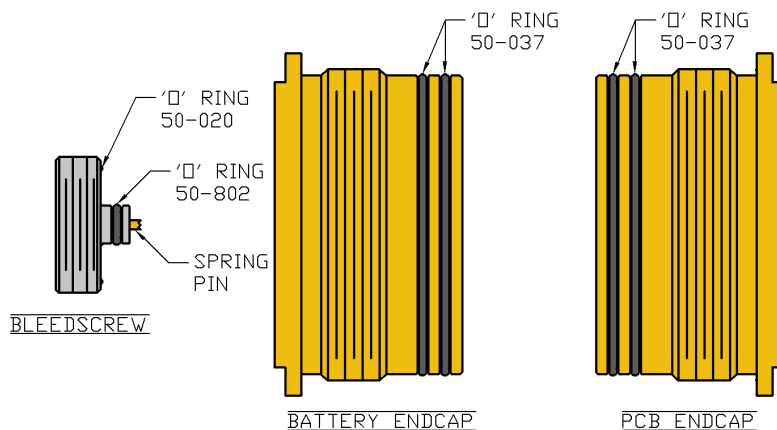

6. Examine all surfaces for signs of corrosion, scoring, and other damage. If there is excessive damage the mechanical parts may need to be replaced.
7. Lightly grease all sealing surfaces using a suitable grease (e.g. DOW CORNING MOLYKOTE 111 COMPOUND).
8. Lightly grease each O-ring with a suitable grease (e.g. DOW CORNING MOLYKOTE 111 COMPOUND) before fitting.
9. Referring to Section 4.8 BATTERY REPLACEMENT re-insert the batteries and battery discs, then refit the BATTERY ENDCAP to the BATTERY end of the housing and the PCB ENDCAP to the PCB end of the housing using the ENDCAP REMOVAL TOOL. Do not use a vice or spanner, the endcaps only need to be hand tight.
10. Tighten the M5 grub screw on each ENDCAP (until the grub screw engages with the housing to lock each endcap in place). Note that very little torque is required. Damage may occur if over tightened.
11. Examine the bleedscrew spring pin for any signs of damage, ensure it is not stuck and has a smooth travel of approximately 3mm. Fully tighten the bleed screw then loosen the bleed screw 3 full turns to switch the transmitter off and use some tape to hold the bleed screw in this position to prevent it being lost or the transmitter being accidentally turned back on.

5.2. ROUTINE MAINTENANCE AND STORAGE

All Online Electronics Ltd transmitters are designed to require minimum maintenance. The housing should be cleaned using fresh water and cleaning agents as necessary (e.g. WD40). Do not use chemicals which could be damaging to the housing or O-rings.

Check flame paths / threads on the housing body and endcaps for signs of corrosion or damage. If badly pitted or damaged, replace the relevant component.

All components that are replaced must be in accordance with the manufacturers' specifications. Failure to use such components may invalidate the certification/approval and may make the equipment dangerous.

Online Electronics Ltd can supply redress kits containing a complete set of replacement batteries, O-rings, O-ring grease, battery discs and endcap locking screws, contact Online Electronics Ltd for more information.

If the transmitter is to be placed in storage for a long period of time, remove the batteries and battery discs from the transmitter and store separately.

As a minimum the bleed screw must be loosened 3 full turns to switch the transmitter off.

The Transmitter is shipped with a nylon washer underneath the bleed screw to prevent the unit being accidentally switched on in transit. This washer must be removed before the transmitter can be turned on.

6. DISPOSAL OF UNIT

Online Electronics Ltd (OEL) takes its responsibilities under the WEEE Regulations extremely seriously and has taken steps to be compliant in line with our corporate and social responsibilities. In the UK, OEL has joined a registered compliance scheme WeeeCare (registration number **WEE/MP3538PZ/SCH**).

Electrical and electronic equipment should never be disposed of with general waste but must be separately collected for the proper treatment and recovery.

The crossed-out bin symbol, placed on the product, reminds you of the need to dispose of it correctly at the end of its life.

When buying a new product you will have the possibility to return, free of charge, another end of life product of equivalent type that has fulfilled the same functions as the supplied equipment. These items may be deposited at:

Online Electronics Ltd
Online House
Blackburn Business Park
Woodburn Road
Aberdeen
AB21 0PS
UK

Alternatively, to arrange a collection of any waste electrical equipment, obligated to OEL please telephone WeeeCare on **0844 800 2004**.

7. WARRANTY

Online products are guaranteed for one year from the date of purchase. Goods should be returned transportation prepaid to Online Electronics Limited.

There is no charge for parts or labour should any product require repair due to a manufacturing deficiency during the guarantee period.

In the event of a manufacturing deficiency the inward transportation costs will be repaid to the client.

8. APPENDIX A – ATEX SPECIFIC INSTRUCTIONS

EQUIPMENT: 3015X EM transmitters

MANUFACTURER: **Online Electronics Ltd**
Online House
Blackburn Business Park
Woodburn Road
Blackburn
Aberdeen
AB21 0PS
UK
Tel: +44 (0) 1224 714 714
Web: www.online-electronics.com

NOTIFIED BODY NUMBER: 2812

ATEX CERTIFICATE: TRAC 09 ATEX 21218X

MARKINGS:  II 2 G Ex d IIB T4..T6X

APPLICABLE STANDARDS: EN 60079-0:2012+A11:2013
EN 60079-1:2014

SPECIAL CONDITIONS FOR SAFE USE:

1. The temperature class is reliant on the operating ambient temperature as follows:

Ambient temperature	T Class
-20°C to +40°C	T6
-20°C to +80°C	T4

2. Warning – Do not open when an explosive atmosphere may be present.
3. Use only ALKALINE, 1.5V, 18Ah, D cells, rated for at least 250mA continuous current (DURACELL INDUSTRIAL ID1300 recommended).
4. Enclosures manufactured from titanium must be installed such that ignition sources due to impact and friction sparks are excluded.